

The 'Hodson' Induction Kit



EM1973-001

Description:

The '**Hodson INDUCTION KIT**' is a set of parts that permits the student to study and experiment on aspects of Magnetic Induction, Transformers and AC/DC Motor theory. Students wind their own coils, assemble their own iron circuits, connect to low voltage power supplies and connect amp and volt meters.

For safety, mains voltages are NOT used. Please supervise this.

A 'Squirrel Cage' Induction Motor is in the kit for study and understanding of this style of AC motor. The Kit is compatible with the popular 'Hodson' Motor Kit and this small DC motor will run when the "U" core is used as the DC field. Advanced AC theory and resonance can be studied by making chokes and using capacitors.

The instructor can adapt the kit for other purposes, like measuring the holding strength of an electromagnet or comparing the holding strength between an AC and a DC magnet, or making a vibrator or a buzzer and so on.

The kit is to be used in conjunction with text book experiments. The information and theory is general and is not intended to replace curriculum experiments.

Length: 310mm	Width: 165mm	Height: 115mm	Weight: 2.6kg
---------------	--------------	---------------	---------------



Kit Contents:

- 1 set “U” laminations, 16mm thick, mounted in plastic frame.
- 1 set “I” laminations, 16mm thick, mounted in plastic frame.
- 1 pce. Plastic frame, empty, to carry rotor and to hold iron cores and devices.
- 2 pcs. Plastic frame, small, to hold short cores and to carry disc axle.
- 1 pce. Iron bar, 16x16 square x 96mm long.
- 2 pcs. Iron bars, 16x16 square x 48mm long.
- 4 pcs. Coil bobbins for winding coils. Red, Yellow, Blue, Green. With coil fronts.
Red coil is pre-wound 300 turns and connected to 4mm sockets as the primary coil.
Another coil is pre-wound to 600 turns as a secondary and connected to 4mm sockets.
- 1 pce. Handle for holding bobbins during winding.
- 1 pce. Induction motor, AC, laminated frame, rotor, ball races and end shields.
- 1 pcs. Reel of insulated wire, large, for winding all coil bobbins.
- 1 pce. Instruction sheet and experiment manual.

The following items are in a separate zip bag:

- 1 set Cables, 1 pair red/black, 2 each yellow and blue, with stackable banana plugs.
- 1 set 3 red / 3 black Alligator clips.
- 4 pcs. Sockets, brass with lugs and screws, to make 4mm sockets for permanent coils.
- 1 pce. Rotor, plastic (2 halves), to carry small magnets, for studying basic AC motor theory.
- 2 pcs. Small cylindrical permanent magnets for placing into plastic rotor.
- 2 pcs. Bar magnets, 75mm long, for induction experiments.
- 1 pce. Disc, aluminium, with rubber centre, for eddy current experiments.
- 1 pce. Axle for supporting and spinning aluminium disc.
- 1 pce. Ring of aluminium for ‘Thompson’s Ring’ demonstration.
- 8 pcs. Elastic bands to stretch tightly between holder legs to pull core together.
- 1 pce. Plate, aluminium, to carry ‘Hodson’ DC motor assembly.
Note: The Hodson Motor Kit is not supplied as part of this kit.
- 1 pce. Magnetic compass for determining polarity of magnetic poles.

Designed and manufactured in Australia

Parts Identification:

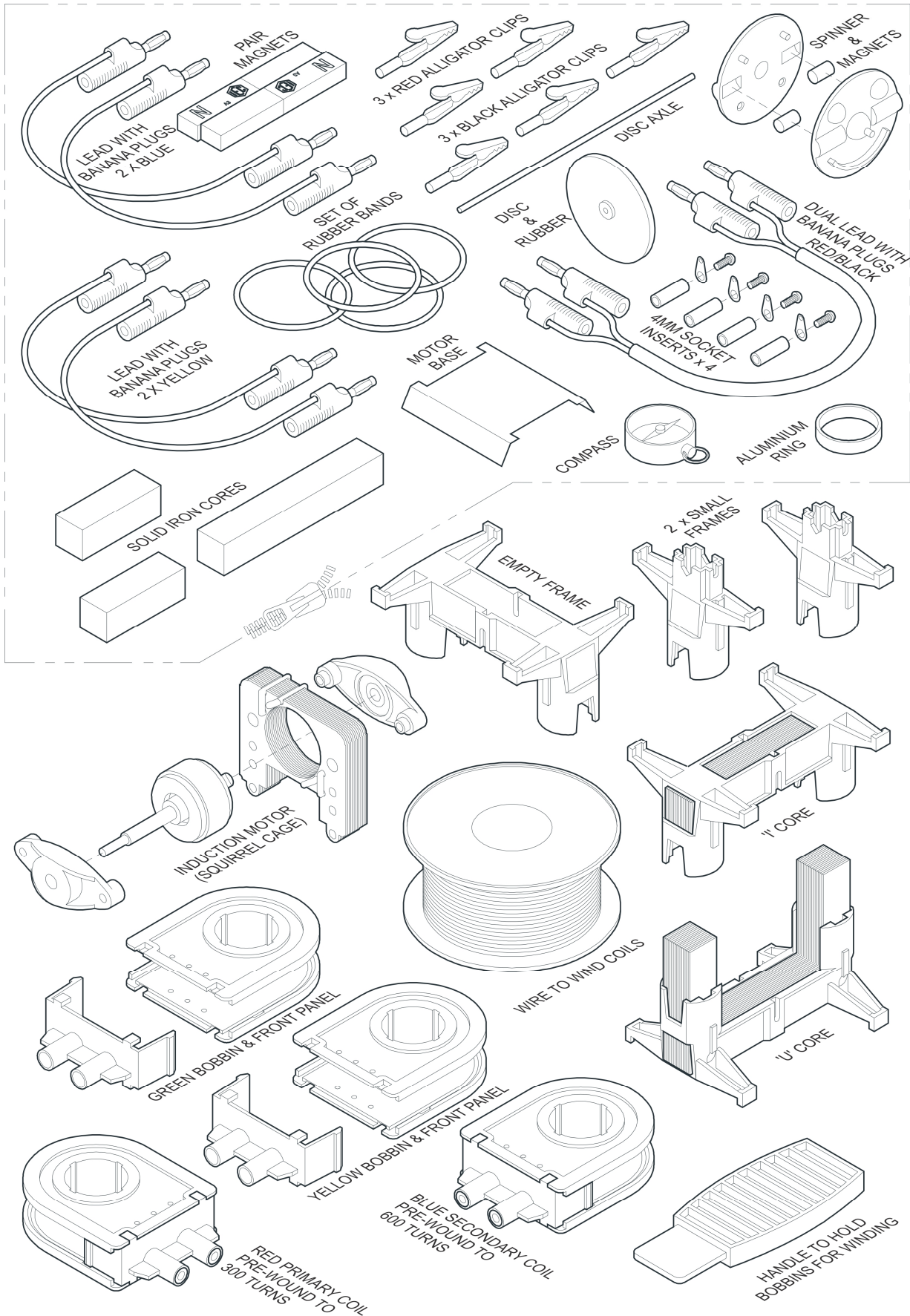

INDUSTRIAL EQUIPMENT & CONTROL PTY.LTD.

61-65 McClure St. Thornbury. 3071 Melbourne. Australia

Tel: 61 (0)3 9497 2555

Email: iec@iecipl.com.au

www.iecipl.com.au